



EMN90-CHX

Ver. 5 Rel. 2/11/2026

ELITE PI®
 Standard / MAX

VERTICAL

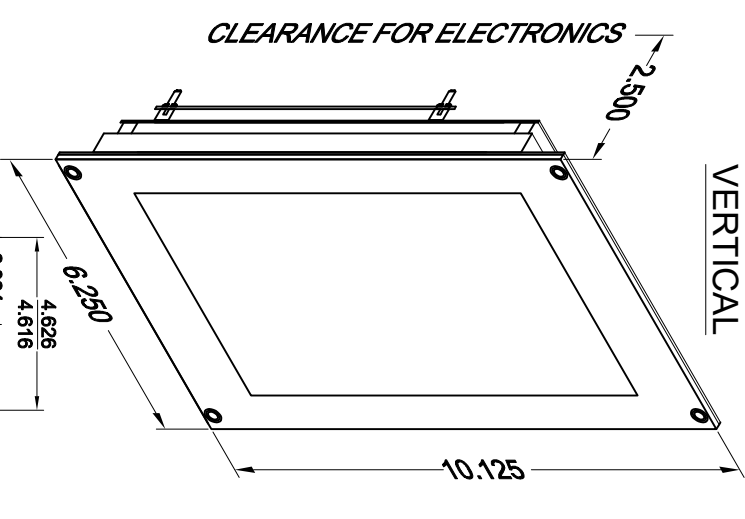

HORIZONTAL

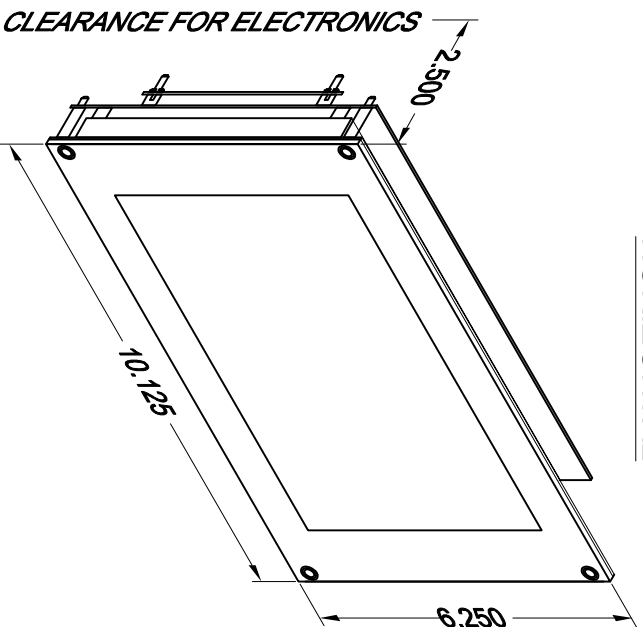

9.0 Inch Elite PI® Standard / MAX

The MICRO COMM® Elite PI® Standard is the entry level platform for a property looking for something more than a typical position indicator. With a full 256 color TFT screen, the Elite PI® Standard can be customized with your property logo or an image of the building. This position indicator is capable of relaying information to passengers regarding the elevator's current position and direction, arrival arrows, along with priority messages from the controller. It's also designed to be a destination type display showing floors served when in destination mode. These units also have a non-movement selectable time blanking to help preserve backlight life. The Elite PI® Standard doesn't support custom customer messages; for custom content management on the display, choose the Elite PI® PRO product line.

Typical Applications

- Car operating panel
- Car transom
- Lobby/arrival
- Destination Display

Features:

- Passing chime output
- Self testing
- Low voltage
- Backlight saver function / default on 30 min.
- USB Updatable
- MICRO COMM® input
- Voice capabilities

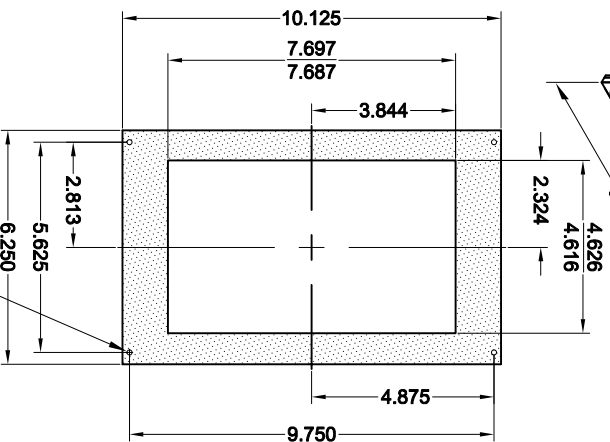

PANEL PREP

~ Some features may not be available for your system. Please check with your manufacturer or engineering for special features. ~

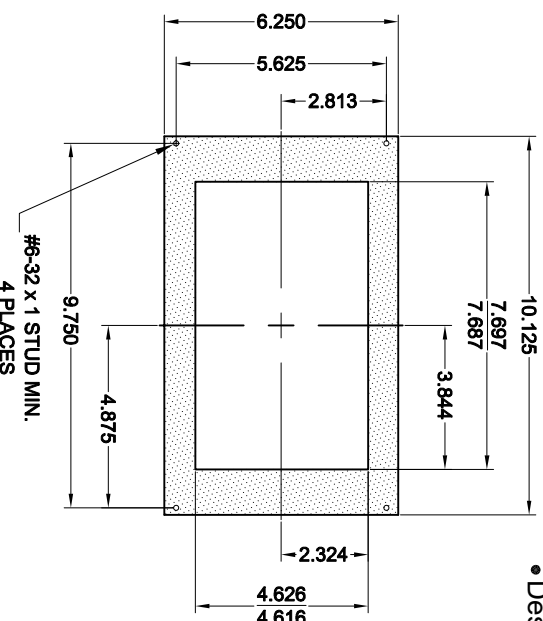

PANEL PREP

TO ORDER: - EMN90 - CHX

"H" = HORIZONTAL (Landscape)
 "V" = VERTICAL (Portrait)

HORIZONTAL RELATED DRAWINGS	
DESCRIPTION	DRAWING NAME
PANEL PREP.	PP90-5
DETAIL DIM.	DD90-5
VERTICAL RELATED DRAWINGS	
DESCRIPTION	DRAWING NAME
PANEL PREP.	PP90-6
DETAIL DIM.	DD90-6