

# EMN104-ACX

10.4" ELITE PI STANDARD / MAX



## ELITE PI® Standard

10.4" ELITE PI STANDARD / MAX

The MICRO COMM® Elite PI® Standard is the entry level platform for a property looking for something more than a typical position indicator. With a full 256 color TFT screen, the Elite PI® Standard can be customized with your property logo or an image of the building. This position indicator is capable of relaying information to passengers regarding the elevator's current position and direction, arrival arrows, along with priority messages from the controller. It's also designed to be a destination type display showing floors served when in destination mode. These units also have a non-movement selectable time blanking to help preserve backlight life.

The Elite PI® Standard doesn't support custom customer messages; for custom content management on the display, choose the Elite PI® PRO product line.

### TYPICAL APPLICATIONS:

- > Car Operating Panel
- > Car Transom
- > Lobby/arrival
- > Destination Display

### FEATURES:

- > Passing Chime Output
- > Self Testing
- > Low Voltage
- > Backlight Saver Function / Default on 30 Minutes
- > USB Updatable
- > MicroComm® Input
- > Voice Capabilities



**C.E. Electronics, Inc. (US)** 2107 Industrial Drive, Bryan, Ohio 43506 p: 419.636.6705 [www.ceelectronics.com](http://www.ceelectronics.com)

**C.E. Electronics, Ltd. (UK)** P.O. Box 1679 Marlow, Bucks SL7 3ZG, UK p: +44 (0) 1628 487633 [www.ceelectronics.co.uk](http://www.ceelectronics.co.uk)



# EMN104-ACX

Ver. 9 Rel. 2/11/2026

ELITE PI®  
 Standard / MAX

## VERTICAL

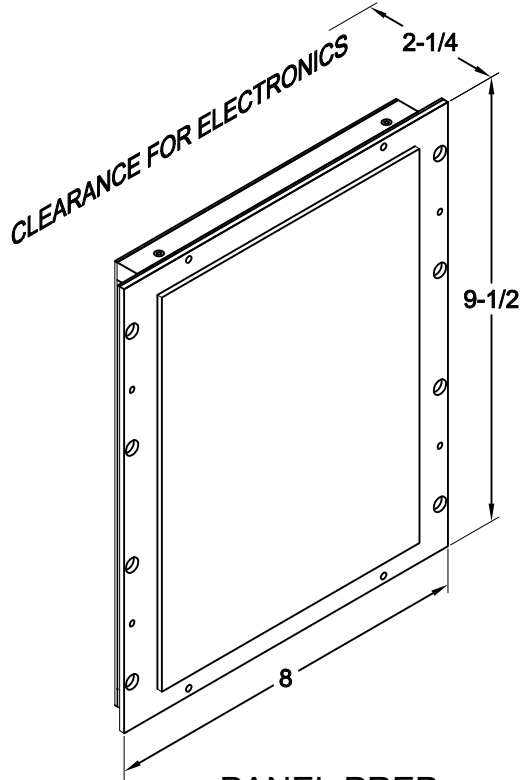

## HORIZONTAL

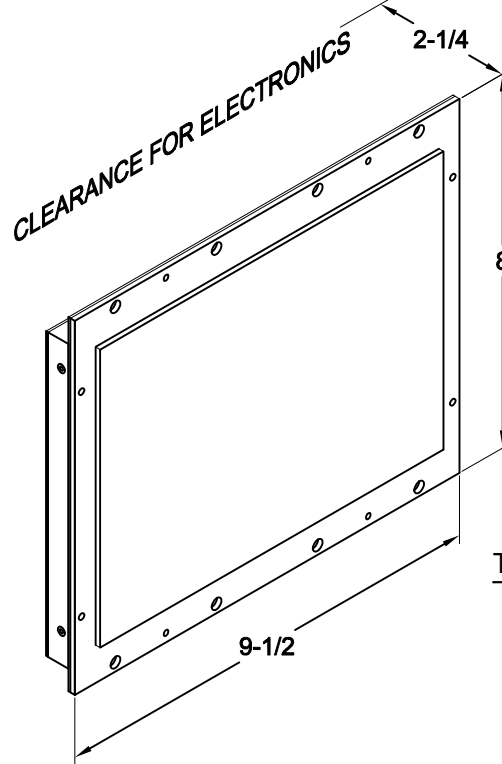

### 10.4 Inch Elite PI® Standard / MAX

The MICRO COMM® Elite PI® Standard is the entry level platform for a property looking for something more than a typical position indicator. With a full 256 color TFT screen, the Elite PI® Standard can be customized with your property logo or an image of the building. This position indicator is capable of relaying information to passengers regarding the elevator's current position and direction, arrival arrows, along with priority messages from the controller. It's also designed to be a destination type display showing floors served when in destination mode. These units also have a non-movement selectable time blanking to help preserve backlight life. The Elite PI® Standard doesn't support custom customer messages; for custom content management on the display, choose the Elite PI® PRO product line.

#### Typical Applications

- Car operating panel
- Car transom
- Lobby/arrival
- Destination Display

#### Features:

- Passing chime output
- Self testing
- Low voltage
- Backlight saver function / default on 30 min.
- USB Updatable
- MICRO COMM® input
- Voice capabilities

### PANEL PREP

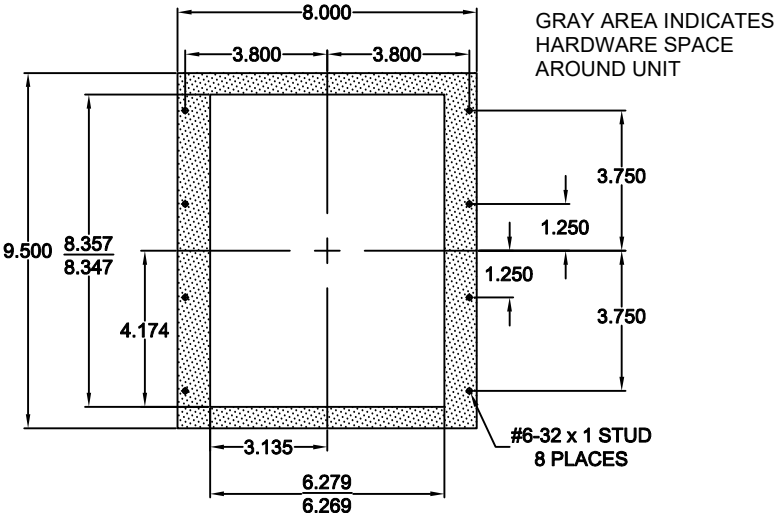

### PANEL PREP

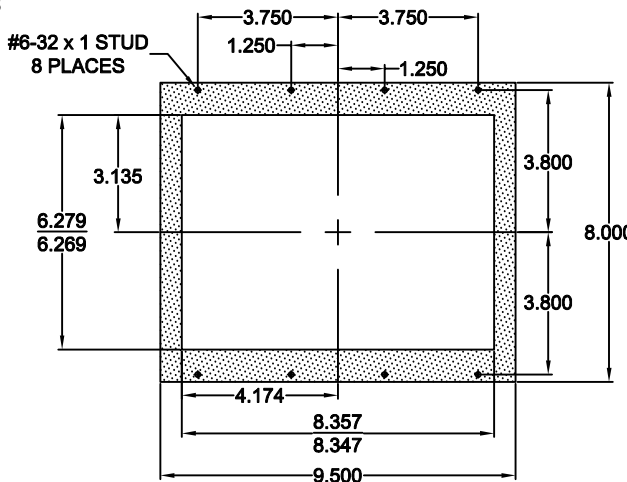

**TO ORDER: - EMN104 - ACX**

"H" = HORIZONTAL (Landscape)  
 "V" = VERTICAL (Portrait)

HORIZONTAL RELATED DRAWINGS	
DESCRIPTION	DRAWING NAME
PANEL PREP.	PP104-12
DETAIL DIM.	DD104-12
VERTICAL RELATED DRAWINGS	
DESCRIPTION	DRAWING NAME
PANEL PREP.	PP104-13
DETAIL DIM.	DD104-13

~ Some features may not be available for your system. Please check with your manufacture or engineering for special features. ~

# EMN104

JOB# \_\_\_\_\_

CE3938 \_\_\_\_

CODE VERSION \_\_\_\_\_

DESIGN VERSION \_\_\_\_\_

AUDIO VERSION \_\_\_\_\_

CRCG \_\_\_\_\_ OCDL CRC \_\_\_\_\_

CRCA \_\_\_\_\_ ODAACRC \_\_\_\_\_

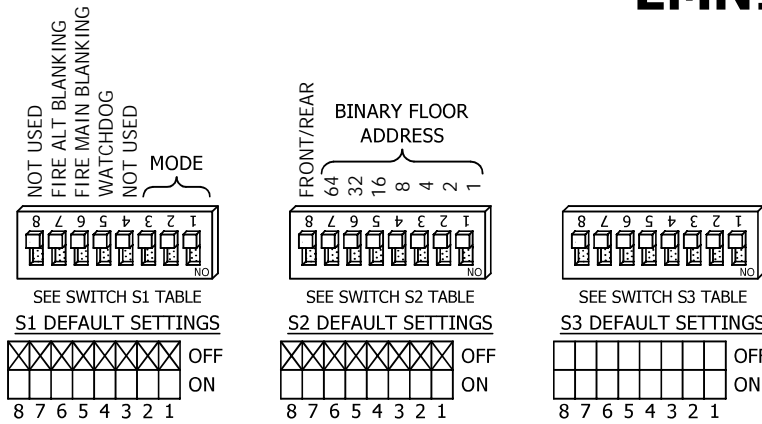

SWITCH S1

DS1	DS2	DS3	S1 MODE FUNCTIONS
OFF	OFF	OFF	NORMAL OPERATION
ON	OFF	OFF	DISPLAY TEST MODE
ON	ON	OFF	AUDIO / UNIT TEST MODE

SWITCH S2 - ARRIVAL ARROWS  
DS1 - DS7 set the unit's floor number.

DS7 (64)	DS6 (32)	DS5 (16)	DS4 (8)	DS3 (4)	DS2 (2)	DS1 (1)	FLOOR NUMBER
OFF	OFF	OFF	OFF	OFF	OFF	ON	CAR UNIT*
OFF	OFF	OFF	OFF	OFF	OFF	ON	FLOOR 1
OFF	OFF	OFF	OFF	OFF	ON	OFF	FLOOR 2
OFF	OFF	OFF	OFF	OFF	ON	ON	FLOOR 3
OFF	OFF	OFF	OFF	ON	OFF	ON	FLOOR 4
OFF	OFF	OFF	OFF	ON	OFF	ON	FLOOR 5
ON	ON	ON	ON	ON	OFF	ON	FLOOR 125
ON	ON	ON	ON	ON	ON	OFF	FLOOR 126
ON	ON	ON	ON	ON	ON	ON	IN-CAR UNIT**

DIP switch S2 - Switch 8 sets the unit as front or rear.  
DS8 OFF - Front Unit DS8 ON - Rear Unit

\*CAR UNIT - Unit uses the Hall Arrival Lantern Signals for the current floor.

\*\*IN-CAR UNIT - Unit uses the In-Car Arrow signals.

DS8	DS7	DS6	DS5	DS4	DS3	DS2	DS1	S3 FUNCTIONS
OFF	OFF	OFF	OFF	OFF	OFF	OFF	OFF	NORMAL/RATH OPERATION
ON	ON	ON	ON	ON	ON	ON	ON	MULTI-CAR OPERATION
OFF	ON	OFF	OFF	OFF	OFF	OFF	OFF	EVAC OPERATION

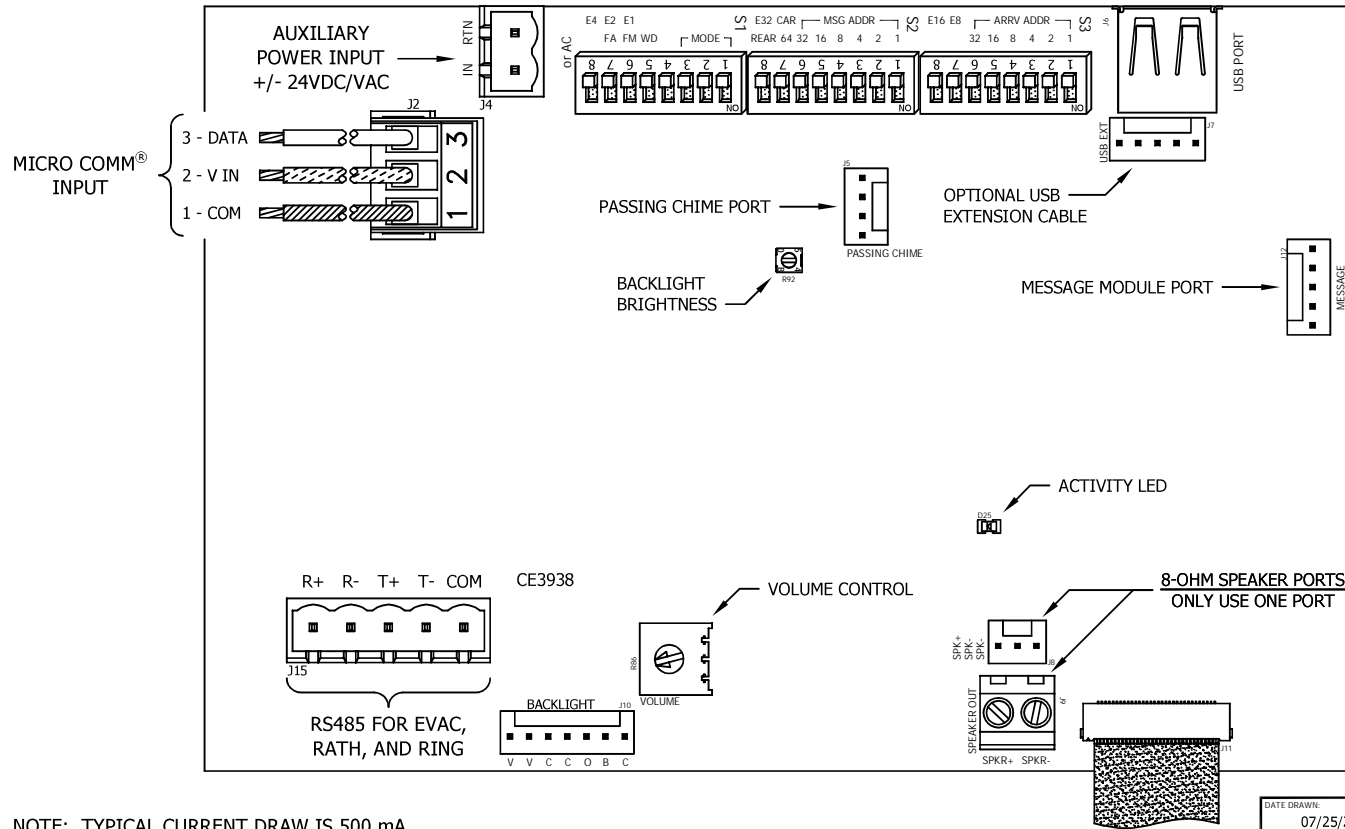

NOTE: TYPICAL CURRENT DRAW IS 500 mA.

DATE DRAWN: 07/25/24	DRAWN BY: DAC	REQUESTED BY: TE	C.E. ELECTRONICS, INC. 2107 Industrial Drive Bryan, OH 43106 (419) 636-6705
BOARD NUMBER: 3938	LAST DATE REVISED: -	APPROVED BY:	
PRODUCT: EMN104 - ELITE STANDARD 10.4" TFT DISPLAY	DWG. NO. EMNTFT_01	REV: -	

# DD104-12

Ver. 2 Rel. 11/5/2018

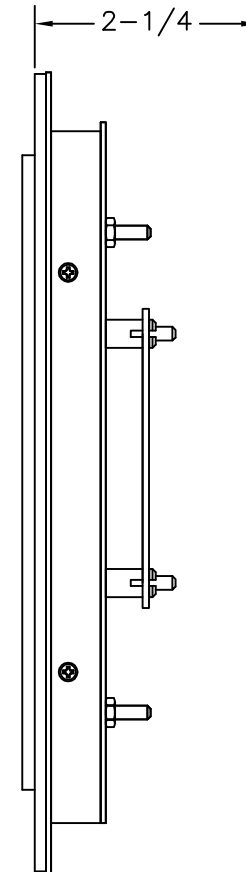
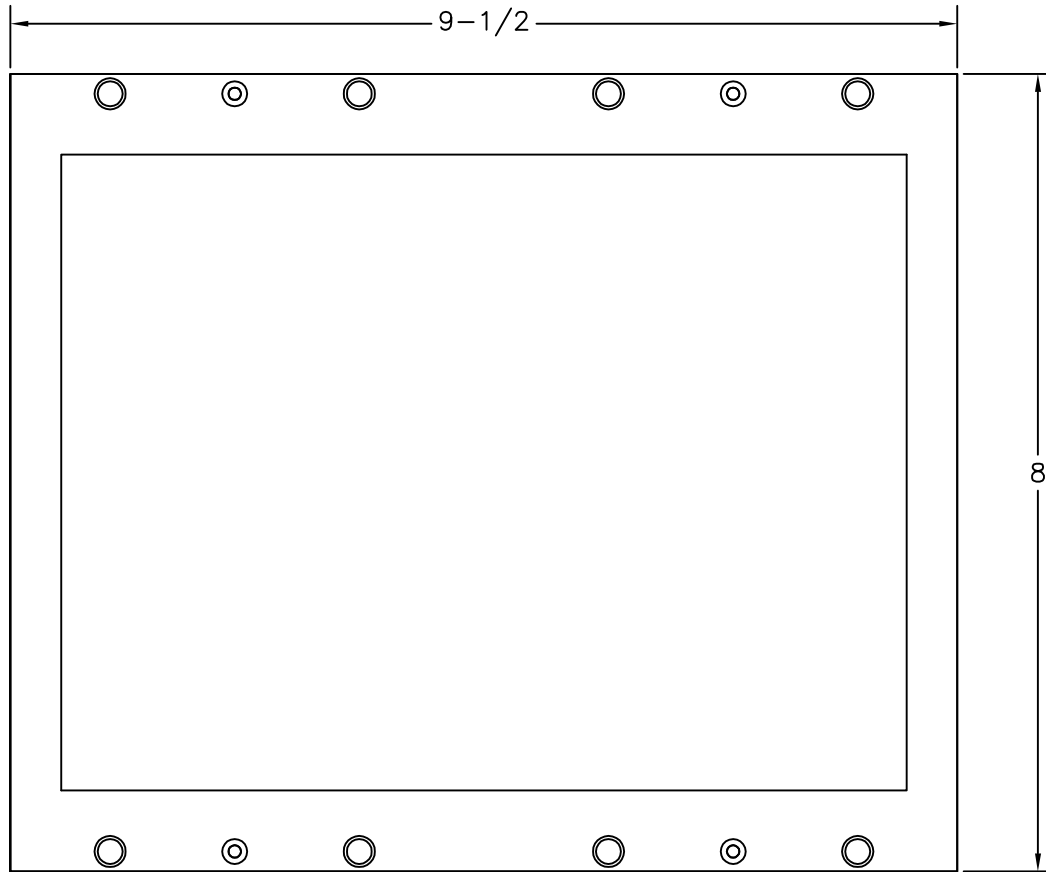

LENS NUMBER:	BOARD # & REV:
APPROVED BY:	
Signature: _____	
Date: _____	
Company: _____	

DATE DRAWN: 12/19/2011	LAST DATE REVISED 11/5/2018	SCALE NONE	PART #:
DRAWN BY: DWS	TOLERANCE UNLESS OTHERWISE SPECIFIED:		 C.E. ELECTRONICS, INC. 2107 Industrial Drive Bryan, Ohio 43506 (419) 636-6705
REQUESTED BY:	TOLERANCE FOR CUTOUT (WINDOW):		
TITLE: DETAIL DIM FOR EMN104-ACH		DWG. NO. DD104-12	REV. B

# DD104-13

Ver. 2 11/5/2018

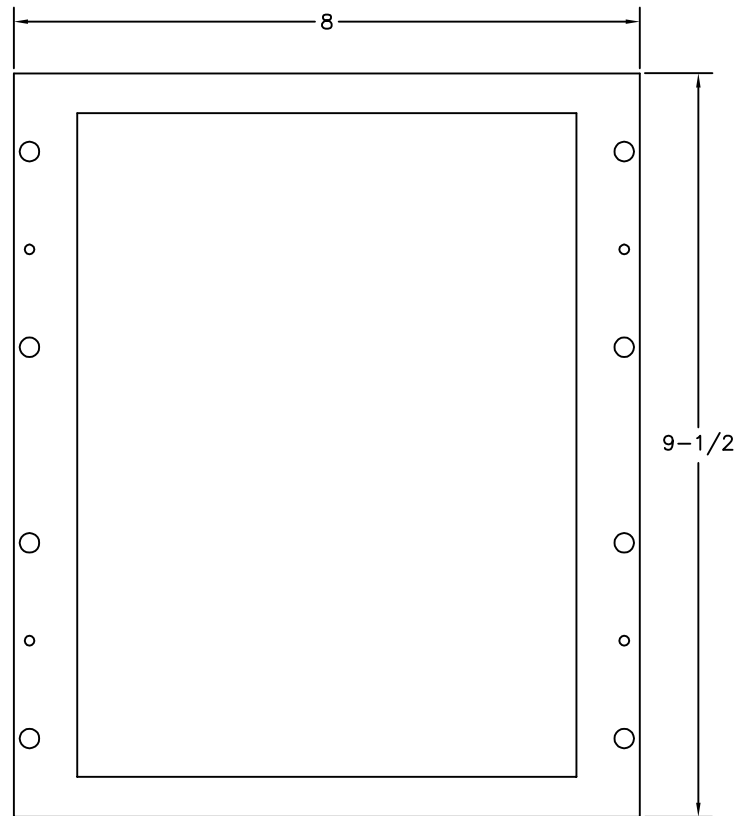
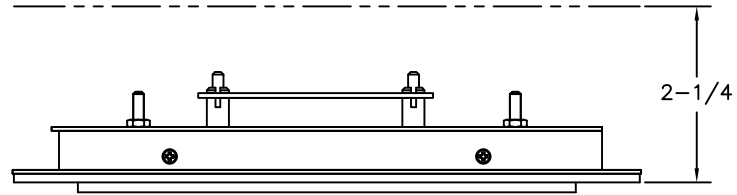

LENS NUMBER:	BOARD # & REV:
APPROVED BY:	
Signature: _____	
Date: _____	
Company: _____	

DATE DRAWN: 12/19/2011	LAST DATE REVISED 11/5/2018	SCALE NONE	PART #:
DRAWN BY: DWS	TOLERANCE UNLESS OTHERWISE SPECIFIED:		 C.E. ELECTRONICS, INC. 2107 Industrial Drive Bryan, Ohio 43506 (419) 636-6705
REQUESTED BY:	TOLERANCE FOR CUTOUT (WINDOW):		
TITLE: DETAIL DIM FOR EMN104-ACV			DWG. NO. DD104-13
			REV. B

# PP104-12

Ver. 1 Rel. 12/20/2011

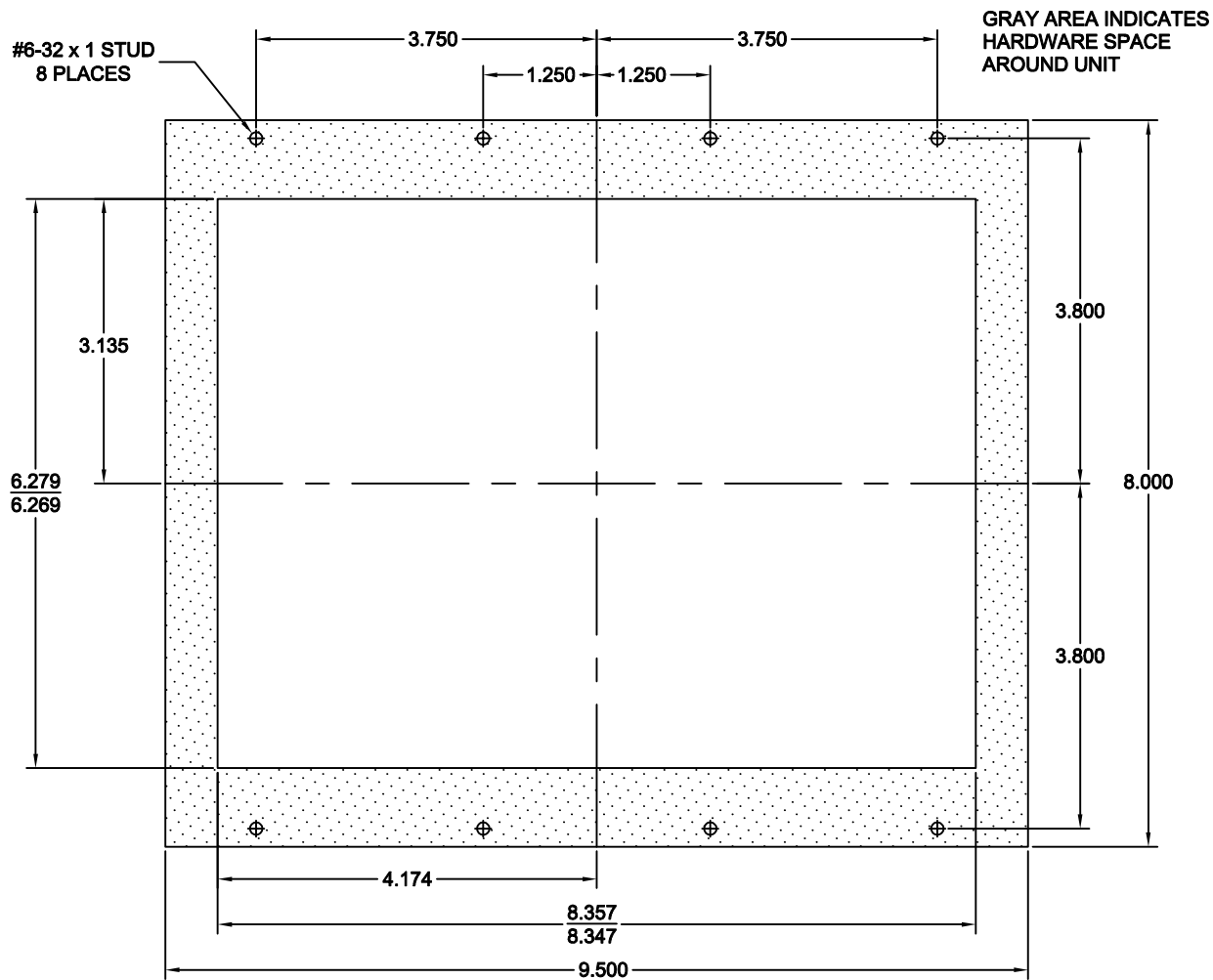

LENS NUMBER:	BOARD # & REV:
APPROVED BY:	
Signature: _____	
Date: _____	
Company: _____	

DATE DRAWN: 10	LAST DATE REVISED:	SCALE NONE	PART #:
DRAWN BY: DWS	TOLERANCE UNLESS OTHERWISE SPECIFIED: ±.015		 <b>C.E. ELECTRONICS, INC.</b> 2107 Industrial Drive Bryan, Ohio 43506 (419) 636-6705
REQUESTED BY: TE	TOLERANCE FOR CUTOUT (WINDOW):		
TITLE: EMN104-ACH PANEL PREP			DWG. NO. PP104-12
			REV:

# PP104-13

Ver. 1 Rel. 12/20/2011

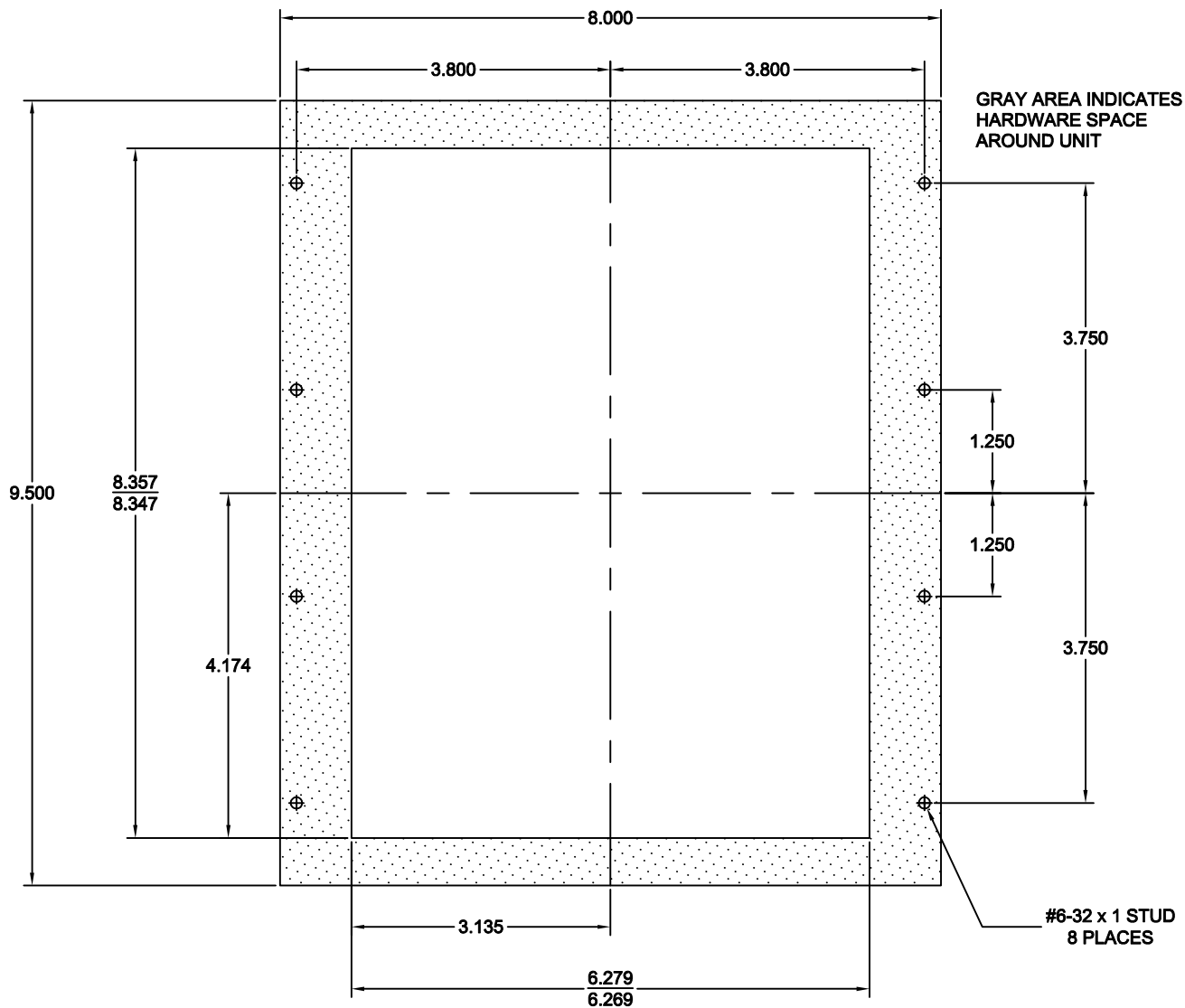

LENS NUMBER:	BOARD # & REV:
APPROVED BY:	
Signature: _____	
Date: _____	
Company: _____	

DATE DRAWN: 12/20/2011	LAST DATE REVISED:	SCALE NONE	PART #:
DRAWN BY: DWS	TOLERANCE UNLESS OTHERWISE SPECIFIED: ±.015		 <b>C.E. ELECTRONICS, INC.</b> 2107 Industrial Drive Bryan, Ohio 43506 (419) 636-6705
REQUESTED BY: TE	TOLERANCE FOR CUTOUT (WINDOW):		
TITLE: EMN104-ACV PANEL PREP			DWG. NO. PP104-13
			REV: