

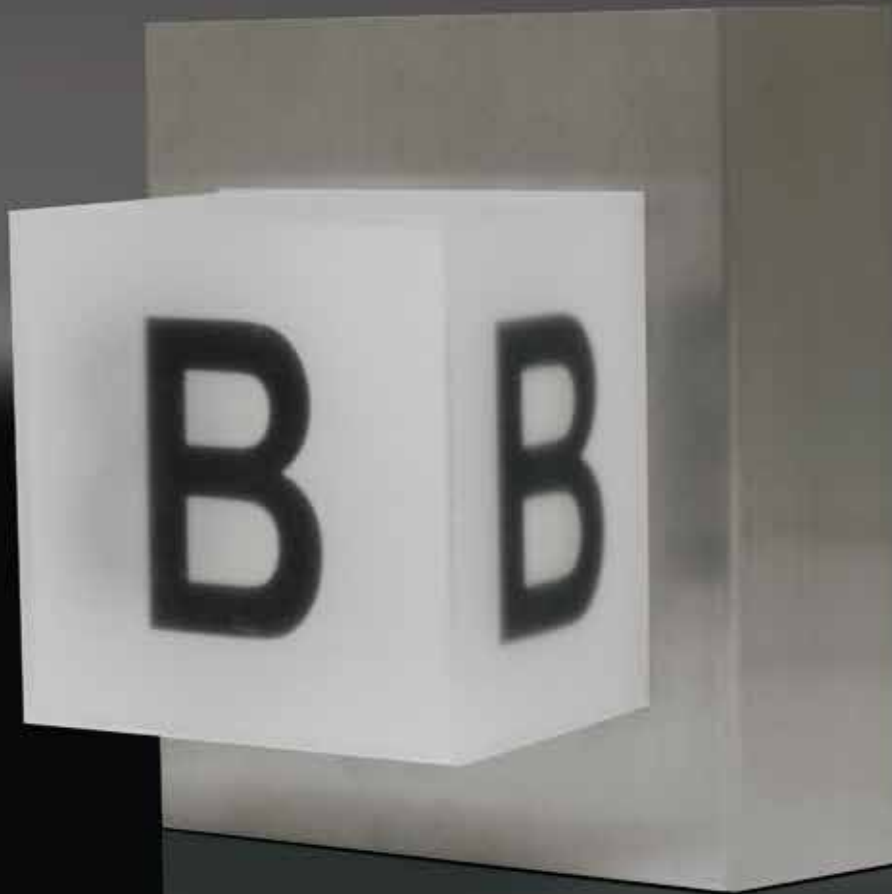

## MCUBE-XXX

LED EXTENDED DESTINATION CUBE



## DESTINATION-BASED

LED EXTENDED DESTINATION CUBE

Long life, solid state LED's with a 100,000 hour rated life. Accepts existing signals over the MICRO COMM link. This is a three sided display giving you 180° viewing. The unit is also equipped with an arrival gong, and destination tones. The programming is dip switch selectable.

### TYPICAL APPLICATIONS:

- > Hall / Destination Display
- > 180° Viewing Angle

### FEATURES:

- > 2" - 3" characters (front view)
- > 180° viewing angle lantern
- > 1 year factory warranty
- > Includes speaker for tones
- > MICRO COMM input
- > Optional destination voice card + additional cost.
- > Note: When adding voice board, this will include our 9SPKRASY03 SPEAKER

### METAL:

- > 70100067 (Applied Mounting)
- > 70100152 (Surface Mount)

### COLORS AVAILABLE:

- Red
- Green
- Amber
- Blue
- White



**C.E. Electronics, Inc. (US)** 2107 Industrial Drive, Bryan, Ohio 43506 p: 419.636.6705 [www.cееlectronics.com](http://www.cееlectronics.com)

**C.E. Electronics, Ltd. (UK)** P.O. Box 1679 Marlow, Bucks SL7 3ZG, UK p: +44 (0) 1628 487633 [www.cееlectronics.co.uk](http://www.cееlectronics.co.uk)



# MCUBE-XXX

Ver. 3 Rel. 3/22/2021

DESTINATION  
BASED

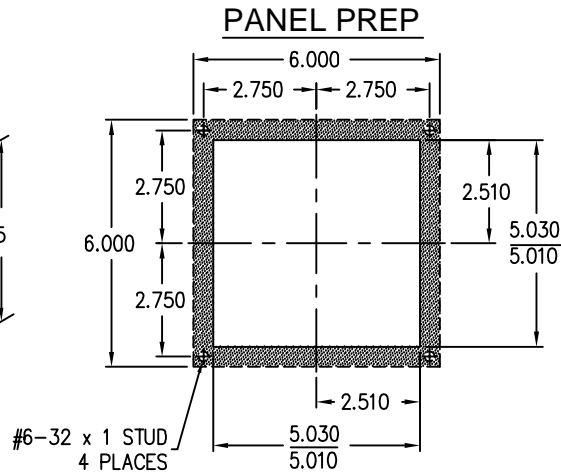
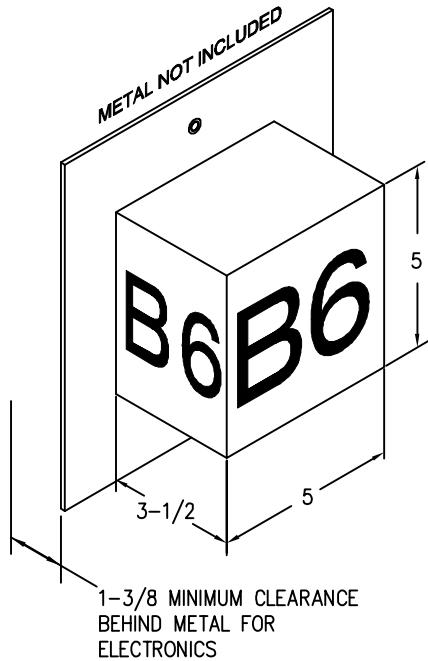

## DESTINATION SPEAKER (9SPKRASY03)

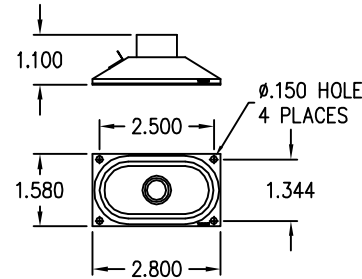

## MCUBE

### LED EXTENDED DESTINATION CUBE

Long life, solid state LED's with a 100,000 hour rated life. Accepts existing signals over the MICRO COMM link. This is a three sided display giving you 180° viewing. The unit is also equipped with an arrival speaker and destination tones. The programming is dip switch selectable.

#### Typical Applications

- Hall/Destination Display
- 180° Viewing Angle

#### Features:

- 2 Inch - 3 Inch characters (Front View)
  - 180° viewing angle lantern
  - 1 year factory warranty
  - Includes Speaker for tones
  - MICRO COMM input
  - Optional destination voice card - additional cost
- Note: when adding voice board, this will include our 9SPKRASY03 SPEAKER

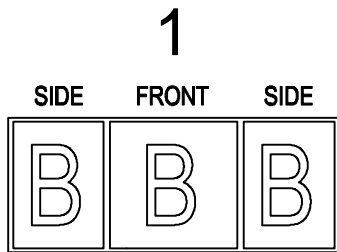

3 inch letters

INSIDE PN-11100173  
 OUTSIDE PN-11100214

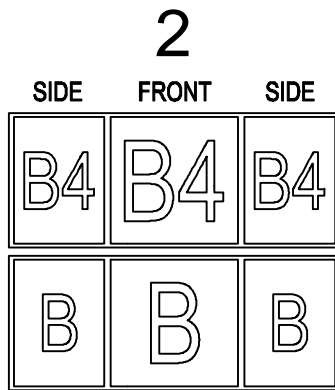

2 inch side & 3 inch front letters

INSIDE PN-11100201  
 OUTSIDE PN-11100211

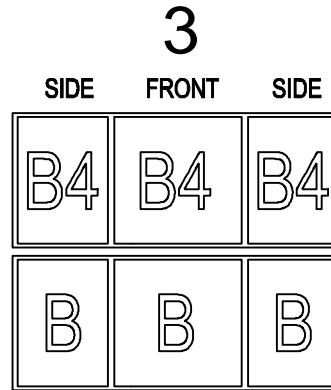

2 inch letters

INSIDE PN-11100202  
 OUTSIDE PN-11100212

TO ORDER: - SPECIFY MCUBE - X X X

"1" = 3 Inch  
 "2" = 3 Inch / 2 Inch  
 "3" = 2 Inch

#### Destination Color:

"R" = Red  
 "G" = Green  
 "B" = Blue  
 "W" = White  
 "A" = Amber

"BLANK" = No Voice  
 "D" = Destination Voice w/Speaker

NOTE: Lead times vary and characters need to be specified.

~ Some features may not be available for your system. Please check with your manufacture or engineering for special features. ~

# MCUBE/MLBOX

MICRO COMM®  
INPUT

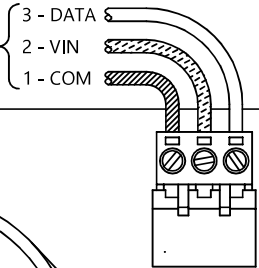

JOB# \_\_\_\_\_

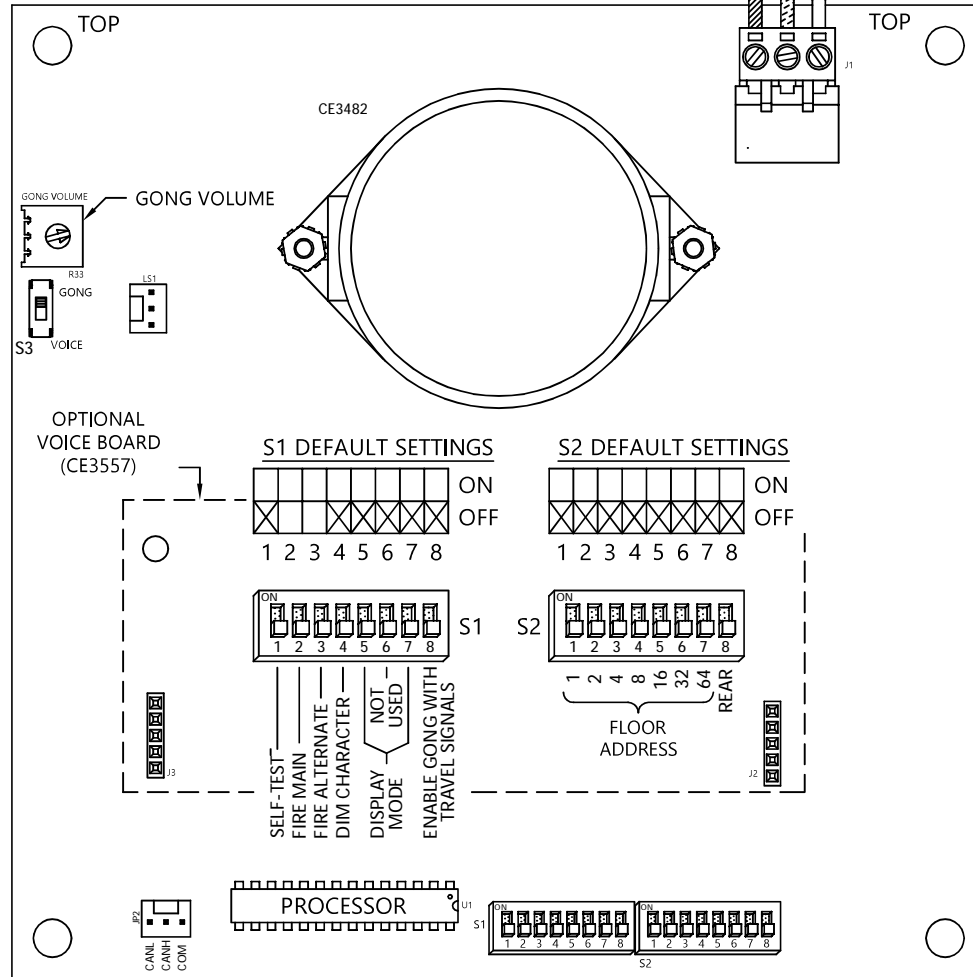

To use the gong option, set the S3 GONG/VOICE switch to GONG. To use the voice option, install the optional CE3557 voice board, and then set the S3 GONG/VOICE switch to VOICE.

Turn on S1-5 to show the floor character instead of arrival arrows.

**NOTE: MUST BE USED WITH A CLASS 2 POWER SUPPLY**

CODE VERSION \_\_\_\_\_

BOARD VERSION CE3482 \_\_\_\_\_

S1-5	S1-7	DISPLAY MODE
OFF	OFF	SHOW ARROWS
OFF	ON	SHOW CHARACTER
ON	OFF	SHOW BOTH
ON	ON	SHOW NEITHER

CHART TO SET FLOOR ADDRESS WITH DIP SWITCH

32 16 8 4 2 1 — BIT VALUE —						32 16 8 4 2 1							
DS6	DS5	DS4	DS3	DS2	DS1	FLOOR	DS6	DS5	DS4	DS3	DS2	DS1	FLOOR
OFF	OFF	OFF	OFF	OFF	OFF	ALL CALL	ON	OFF	OFF	OFF	OFF	OFF	FLOOR 32
OFF	OFF	OFF	OFF	OFF	OFF	FLOOR 1	ON	OFF	OFF	OFF	OFF	ON	FLOOR 33
OFF	OFF	OFF	OFF	ON	ON	FLOOR 2	ON	OFF	OFF	OFF	ON	ON	FLOOR 34
OFF	OFF	OFF	OFF	ON	ON	FLOOR 3	ON	OFF	OFF	OFF	ON	ON	FLOOR 35
OFF	OFF	OFF	ON	OFF	OFF	FLOOR 4	ON	OFF	OFF	ON	OFF	OFF	FLOOR 36
OFF	OFF	OFF	ON	OFF	OFF	FLOOR 5	ON	OFF	OFF	ON	OFF	ON	FLOOR 37
OFF	OFF	OFF	ON	ON	OFF	FLOOR 6	ON	OFF	OFF	ON	ON	OFF	FLOOR 38
OFF	OFF	OFF	ON	ON	ON	FLOOR 7	ON	OFF	OFF	ON	ON	ON	FLOOR 39
OFF	OFF	ON	OFF	OFF	OFF	FLOOR 8	ON	OFF	ON	OFF	OFF	OFF	FLOOR 40
OFF	OFF	ON	OFF	OFF	OFF	FLOOR 9	ON	OFF	ON	OFF	OFF	ON	FLOOR 41
OFF	OFF	ON	OFF	ON	OFF	FLOOR 10	ON	OFF	ON	OFF	ON	OFF	FLOOR 42
OFF	OFF	ON	OFF	ON	ON	FLOOR 11	ON	OFF	ON	OFF	ON	ON	FLOOR 43
OFF	OFF	ON	ON	OFF	OFF	FLOOR 12	ON	OFF	ON	ON	OFF	OFF	FLOOR 44
OFF	OFF	ON	ON	OFF	ON	FLOOR 13	ON	OFF	ON	ON	OFF	ON	FLOOR 45
OFF	OFF	ON	ON	ON	OFF	FLOOR 14	ON	OFF	ON	ON	ON	OFF	FLOOR 46
OFF	OFF	ON	ON	ON	ON	FLOOR 15	ON	OFF	ON	ON	ON	ON	FLOOR 47
OFF	ON	OFF	OFF	OFF	OFF	FLOOR 16	ON	ON	OFF	OFF	OFF	OFF	FLOOR 48
OFF	ON	OFF	OFF	OFF	OFF	FLOOR 17	ON	ON	OFF	OFF	OFF	ON	FLOOR 49
OFF	ON	OFF	OFF	ON	OFF	FLOOR 18	ON	ON	OFF	OFF	ON	OFF	FLOOR 50
OFF	ON	OFF	OFF	ON	ON	FLOOR 19	ON	ON	OFF	OFF	ON	ON	FLOOR 51
OFF	ON	OFF	ON	OFF	OFF	FLOOR 20	ON	ON	OFF	ON	OFF	OFF	FLOOR 52
OFF	ON	OFF	ON	OFF	ON	FLOOR 21	ON	ON	OFF	ON	OFF	ON	FLOOR 53
OFF	ON	OFF	ON	ON	OFF	FLOOR 22	ON	ON	OFF	ON	ON	OFF	FLOOR 54
OFF	ON	OFF	ON	ON	ON	FLOOR 23	ON	ON	OFF	ON	ON	ON	FLOOR 55
OFF	ON	ON	OFF	OFF	OFF	FLOOR 24	ON	ON	ON	OFF	OFF	OFF	FLOOR 56
OFF	ON	ON	OFF	OFF	ON	FLOOR 25	ON	ON	ON	OFF	OFF	ON	FLOOR 57
OFF	ON	ON	OFF	ON	OFF	FLOOR 26	ON	ON	ON	OFF	ON	OFF	FLOOR 58
OFF	ON	ON	OFF	ON	OFF	FLOOR 27	ON	ON	ON	OFF	ON	ON	FLOOR 59
OFF	ON	ON	ON	OFF	OFF	FLOOR 28	ON	ON	ON	ON	OFF	OFF	FLOOR 60
OFF	ON	ON	ON	OFF	ON	FLOOR 29	ON	ON	ON	ON	OFF	ON	FLOOR 61
OFF	ON	ON	ON	ON	OFF	FLOOR 30	ON	ON	ON	ON	ON	OFF	FLOOR 62
OFF	ON	ON	ON	ON	ON	FLOOR 31	ON	ON	ON	ON	ON	ON	FLOOR 63

Use a MICRO COMM® source to send messages with the level required to activate the features listed below.

To blank the display during a fire main (level three) message, turn on DIP switch S1-2 (FM).

To blank the display during a fire alternate (level two) message, turn on DIP switch S1-3 (FA).

Use the above chart to set the DIP switches for the floor address where the unit is located. Set up the MICRO COMM® driver to send arrival information.

Turn off S2-1 to S2-7 to put the display in travel mode. The LEDs use travel information and react to all travel direction changes. Turn on S1-8 to enable the gong to use travel information as well.

Turn on S2-1 to S2-7 to put the unit in "ALL CALL" mode using in-car lantern signals. The LEDs and gong use arrival signals and react to all arrival events, regardless of the floor location of the elevator.

To set the unit for a floor above 63, turn on DIP switch S2-7 (64) and set DIP switches S2-1 through S2-6 as shown on the chart, subtracting 64 from the desired floor number. For example, to set the unit for floor 75, turn on DIP switch S2-7 and set DIP switches S2-1 to S2-6 for floor 11 (75 - 64 = 11).

To use the display as a rear unit, turn on DIP switch S2-8 (REAR). NOTE: The MICRO COMM® source must send the MC2000 data stream to use this feature. Call Tech Support at 419-636-6705 for more information.

DATE DRAWN: 08/18/10	DRAWN BY: DAC	REQUESTED BY: TC	 2107 Industrial Drive Elyria, OH 44038 (419) 636-6705
BOARD NUMBER: 3482	LAST DATE REVISED: 04/20/23	APPROVED BY:	
PRODUCT CUBE DISPLAY WITH MICRO COMM® INPUT			DWG. NO. MCUBE_01
			REV. H

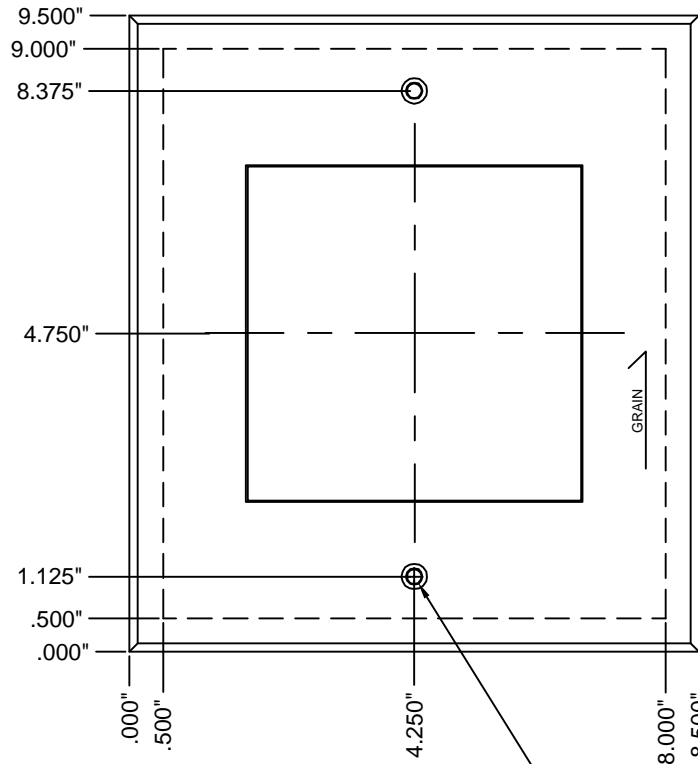
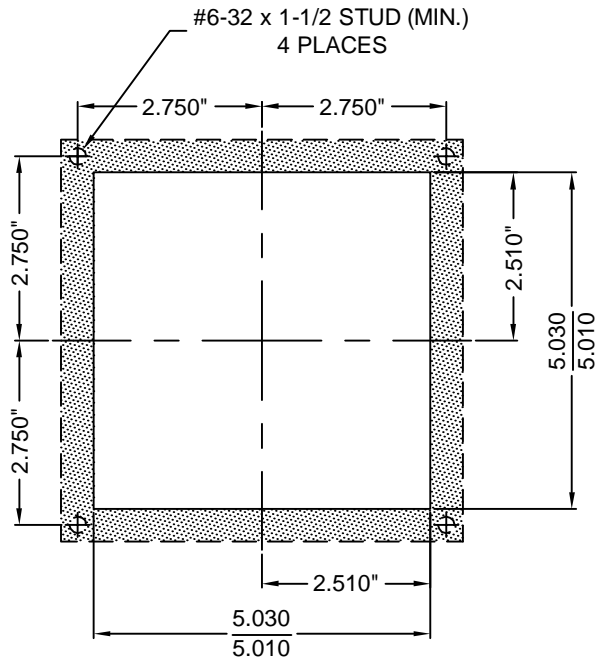

FOR #10 TAMPER PROOF SCREWS  
2 PLACES

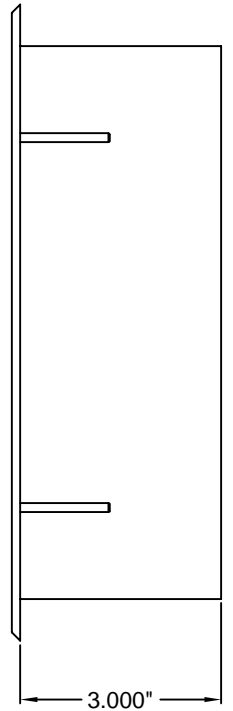

NOTES:

MATERIAL: 11GA. (.13) STAINLESS STEEL  
 FINISH: #4 BRUSHED - VERTICAL GRAIN  
 BEVELED EDGES - APPROXIMATELY 15°  
 BOX REQUIRED, 3" DEEP, NO EXTRUDED BOX  
 VENDOR TO SUPPLY TAMPERPROOF SCREWS AND TINNEMAN CLIPS

LENS NUMBER:	BOARD # & REV:
APPROVED BY:	
Signature: _____	
Date: _____	
Company: _____	

DATE DRAWN: 8/23/2010	LAST DATE REVISED:	SCALE NONE	PART #:
DRAWN BY: DWS	TOLERANCE UNLESS OTHERWISE SPECIFIED: +0.015,-0.015		C.E. ELECTRONICS, INC. 2107 Industrial Drive Bryan, Ohio 43506 (419) 636-6705
REQUESTED BY: CS	TOLERANCE FOR CUTOUT (WINDOW): +0.020,-0.000		
TITLE: CUBE APPLIED MOUNTING FIXTURE - VENDOR			DWG. NO. 70100067-2 REV:

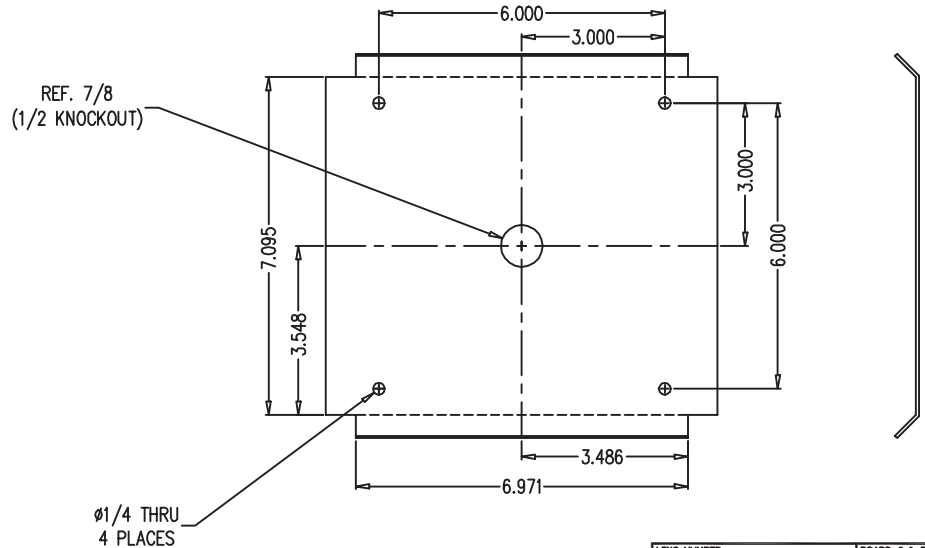
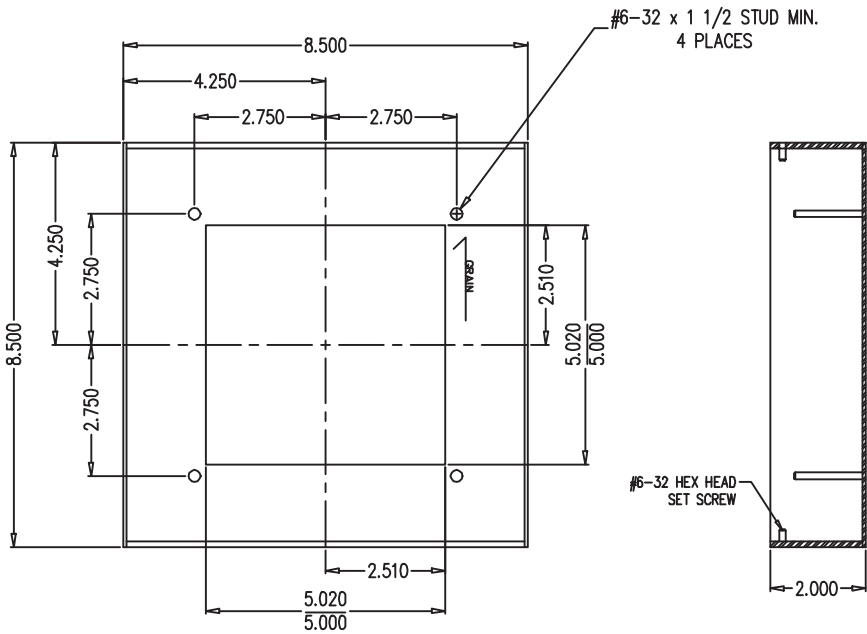
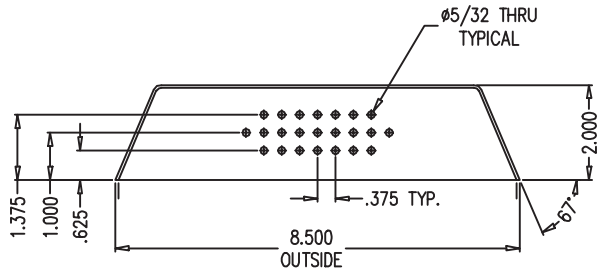

(A) MATERIAL: 16 GA (.06) STAINLESS STEEL  
 FINISH: #4 BRUSHED - VERTICAL GRAIN  
 NOTE: GALVANIZED BACK PLATE INCLUDED

LENS NUMBER:	BOARD # & REV:
APPROVED BY:	
Signature:	
Date:	
Company:	

DATE DRAWN: 10/21/2008	LAST DATE REVISED 1/10/2011	SCALE	PART #
DRAWN BY: RNT	TOLERANCE UNLESS OTHERWISE SPECIFIED: +/- .010		C.E. ELECTRONICS, INC. 2107 Industrial Drive Bryan, Ohio 43506 (419) 836-8705
REQUESTED BY: CS	TOLERANCE FOR CUTOFF (WINDOW): +0.020, -0.000		
TITLE: CUBE ANNUNCIATOR - FIXTURE			DWG. NO. 70100152 REV. A