

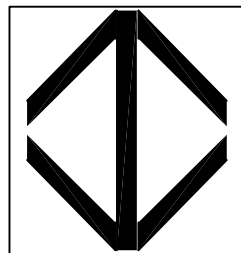

GTDV-XXXX

Ver. 6 Rel. 7/21/2015

CLASSIC
 SERIES

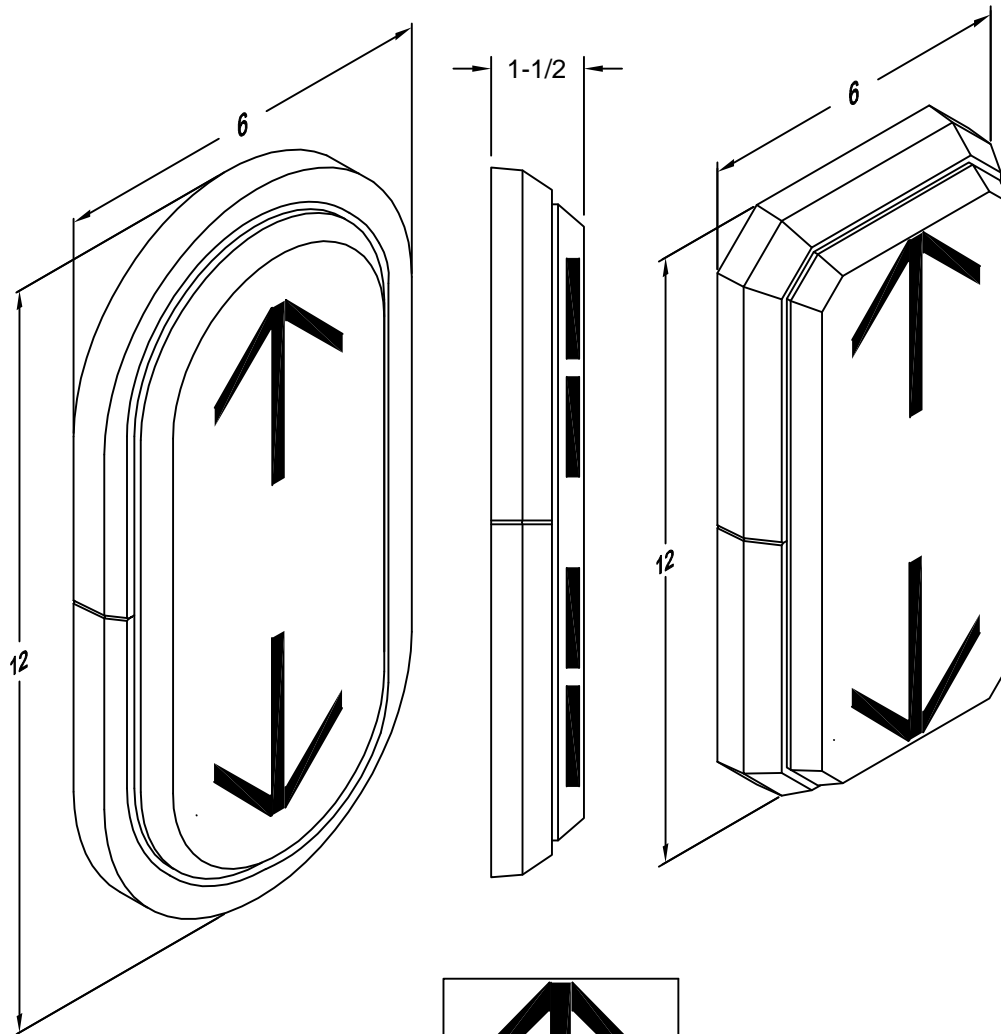

3 INCH ARROW

REMOTE DISPLAY INDICATOR "RDI"

Long life, solid state bi-color, white, green or blue arrow for lanterns, 100,000 hour rated life. Accepts existing signals over the discrete inputs. The bi-color arrows are green in the up direction and red in the down with matching side bars for 180° viewing. The unit is also equipped with an arrival gong.

Typical Applications

- Hall and car lanterns

Features

- Bi-color red & green 3 inch arrow with bi-color side bars or solid blue or solid white or solid green 3 inch arrow with solid color side bar
- Red down/green up or solid blue, solid white, solid green side bar
- 180° viewing angle lantern
- 1 year factory warranty
- Conforms to ADAAG 4.10.4
- Includes gong

TO ORDER - SPECIFY GTDV-XXXX

SIGNAL VOLTAGE:

"B" = 24V

"C" = 115V

"F" = 48VDC; DOUBLE STROKE ONLY

GONG CHOICE:

"S" = SINGLE STROKE

"D" = DOUBLE STROKE

METAL CHOICE:

"A" = STAINLESS STEEL SATIN OVAL

"B" = STAINLESS STEEL CHROME OVAL

"C" = STAINLESS STEEL SATIN RECTANGLE CHAMFERED

"D" = STAINLESS STEEL CHROME RECTANGLE CHAMFERED

"X" = NO METAL

(For additional finishes, contact factory)

<BLANK> = BI-COLOR ARROW

"B" = BLUE ARROW

"G" = GREEN ARROW

"W" = WHITE ARROW